

Twin Tower Mounted Amplifier, Dual Duplexed, AWS

Product Description

Designed for use in AWS projects, these units improve base station receiver sensitivity and enhance coverage. Use of these TMAs can increase data rates without a reduction in capacity. These TMAs are wideband and cover the entire 45 MHz in the AWS frequency band. The unit is extremely lightweight, weighing just 13 lbs (5.9 kg) for a twin unit. It is easy to install and meets IP66 requirements for ingress protection. The TMA has a metallic base and the radome cap is light grey allowing them to blend with antenna radomes. Its dual-duplex configuration enables the use of a single feeder for both Tx and Rx.



Features/Benefits

- **AISG 2.0 compliant**
- **Two TMAs in a single enclosure – reduces tower load and installation time.**
- **Low noise figure overcomes feeder losses and enhances site coverage.**
- **Filtering improves Tx-Rx isolation by reducing noise and interference.**
- **Dual-duplex configuration enables use of a single feeder for both Tx and Rx.**
- **Low insertion loss of Tx filter provides increased downlink coverage.**
- **Extremely light weight – reduces tower loading and facilitates installation.**
- **Equipped with breather valves – guards against internal condensation.**
- **Option: AISG connector location at bottom or top**

Technical Specifications

Electrical Specifications – Rx

| | |
|----------------------------|---|
| AWS Frequency range, MHz | 1710 - 1755 |
| Tx Band rejection, dB | > 80 |
| Gain, dB | 12 +/- 1 |
| Gain ripple, dB | +/- 0.8 |
| Group delay, ns | 160 Max, band edge |
| Group delay variation, ns | < 100 |
| Group delay distortion, ns | < 10 (any 240 kHz) |
| Noise Figure, dB | < 1.05 midband, Typical, Room temperature |
| Output IP3, dBm | > 25 |
| Return Loss, dB | > 18 |

Electrical Specifications – Tx

| | |
|---------------------------|------------------|
| AWS Frequency range, MHz | 2110 - 2155 |
| Rx Band rejection, dB | > 60 |
| Ripple, dB | < +/- 0.1 |
| Group delay, ns | < 10 |
| Group delay variation, ns | < 5 |
| Return loss, dB | >18 |
| Insertion Loss, dB | < 0.4 |
| Power handling, W | 250 cw / 5k peak |

Mechanical Specifications

| | |
|---|--|
| Dimensions, H x D x W, mm (in) | 305 x 254 x 101 (12 x 10 x 4); Includes connector length |
| Weight, kg (lb) (not to exceed) | 5.9 (13) |
| RF Connectors, BTS/Node-B and ANT ports | Long neck DIN 7/16 Female |
| AISG Connector | 8-pin Circular multi-pole, IEC 60130-9;IP67, Hex Nut |
| Mounting | Wall, Pole |
| Orientation | Pole mount upright or sideways, wall mount upright or sideways |

* This data is provisional and subject to change.

All information contained in the present datasheet is subject to confirmation at time of ordering.

Twin Tower Mounted Amplifier, Dual Duplexed, AWS

Technical Specifications

System Specifications

| | |
|---|----------------------|
| Power Supply voltage, Volt | 10-30 |
| IMD @ antenna port with two 43 dBm tones, dBc | < -160 dBc (-117dBm) |
| Antenna Port Power Handling Rx, dBm | 17 |
| Voltage ripple handling | 150 mVp-p amplitude |

TMA operating current drawn from each bias source, mA (AISG products connected to TMA AISG RS-485 port will draw additional current through AWS 1 port)

AISG Mode:

120-200 normal operation, AWS 1 port
 100 ±20 normal operation, AWS 2 port
 190 ±10 alarm condition, AWS 2 port

Non-AISG Mode (Dumb mode*):

100 ±20 normal operation, Both ports
 190 ±10 alarm condition, Both ports

* Dumb mode is defined as the mode when TMA turns off the AISG circuitry in the absence of AISG communication (1 minute after startup). Once in dumb mode, the only way to activate AISG is by power cycling AWS 1 side of the TMA.

| | |
|---------------------|---|
| Impedance, ohms | 50 nominal |
| Polarity protection | No damage if -48 V applied at Node-B port |
| Alarm functionality | AISG 2.0 and 3GPP TS25.461 Compatible |
| Antenna support | AISG / Dual-Band |
| Bias-T | Yes – Internal |

Environmental Specifications

| | |
|---|--------------------------------|
| Operating temperature range, °C | -40 to + 65 |
| Thermal Shock | IEC 68 2-14, Test Na |
| Humidity, % | 20 to 100 |
| Altitude, ft | 11,000 |
| Air Pressure, kPa | 86 to 106 |
| Solar radiation, W/m ² | 1120 |
| Lightning | 8/20 us, 20 kA Multiple pulses |
| EMC | EN 301 489-8 (2002-08) |
| Ingress protection | IP66 |
| Sand and dust | IEC 68-2-18 |
| Salt fog | IEC 68-2-11 |
| Wind load @ 115 km/h (70 mph), N (lb-f) | 50 |
| Wind speed, km/h | > 200 |

Block Diagram

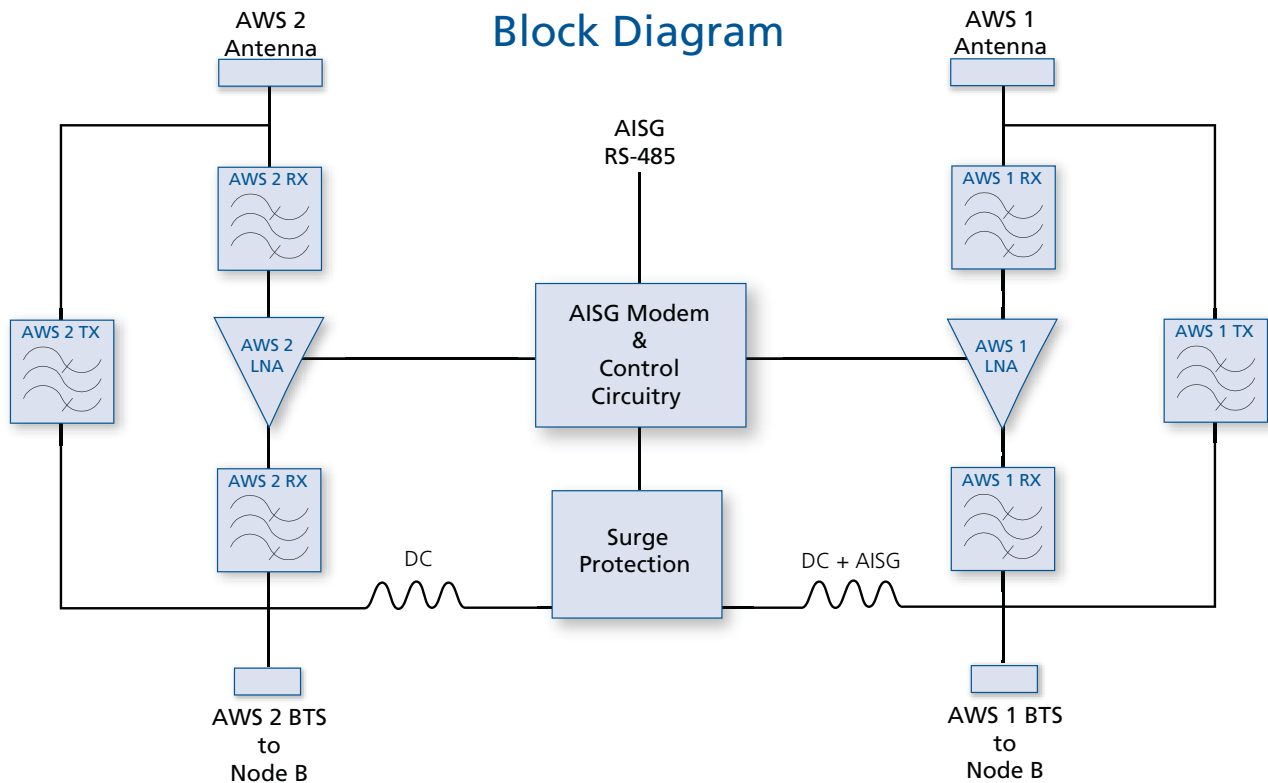

All information contained in the present datasheet is subject to confirmation at time of ordering.